



STT IMP2P



Interrupor médico de pie de 2 pedales USB IP-68

2-Pedal Medical Foot Switches USB IP-68

ESPECIFICACIONES

Pedal

Material	Termoplástico a prueba de golpes
Color	Gris claro (RAL 7035)
Conectividad	Cable de 3 metros, blindado, conector USB
Conmutación	2 contactos normalmente abiertos
Interfaz	Teclado HID "F1" y "F2"
Vida útil mecánica	> 1 millón de ciclos de conmutación

Funcionalidades médicas

Grado de protección	Ingress Protection IP-68
Certificaciones	IEC 60601-1; UL 60601-1; IEC/EN 60529; Clase I de conformidad con la Ley / Directiva sobre dispositivos médicos MDD 93/42/CEE

Entorno

Temperatura	Temp. de funcionamiento: -10°C ~ + 60°C Temp. de almacenamiento: -25°C ~ +70°C
Humedad	Humedad en funcionamiento: 10%~100% Humedad en almacenamiento: 5%~100%

Características físicas

Dimensiones	212 x 42 x 108 mm (Ancho x Alto x Profundo)
-------------	--

SPECIFICATIONS

Pedal

Material	Shock-proof thermoplastic
Colour	Light grey (RAL 7035)
Connectivity	3 meter cable, shielded, USB Connector
Switching	2 normally open contacts
Interface	HID keyboard "F1" and "F2"
Mechanical Life	> 1 million operations

Medical Functionalities

Degree of Protection	Ingress Protection IP-68
Certifications	IEC 60601-1; UL 60601-1; IEC/EN 60529; Class I in accordance with the Medical Devices Act / MDD Directive 93/42/EEC

Environment

Temperature	Operating Temp.: -10°C ~ +60°C Storage Temp.: -25°C ~ +70°C
Humidity	Operating Humidity: 10%~100% Storage Humidity: 5%~100%

Physical Characteristics

Dimensions	212 x 42 x 108 mm (Width x Height x Depth)
------------	---

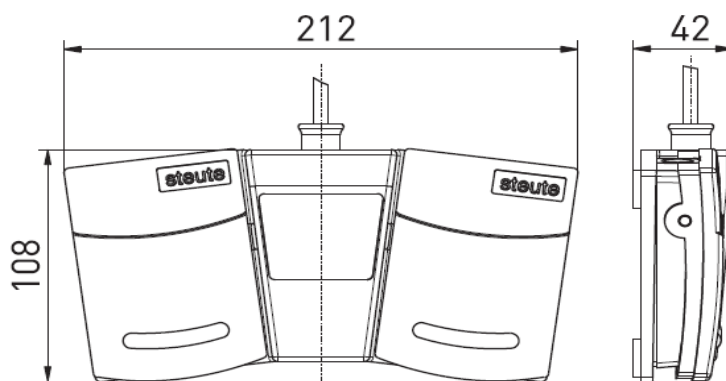

Unidades: mm
Unit: mm